



# Galvashield® Fusion™ T2

Self-Powered Two Stage Anode Series

## DESCRIPTION

Galvashield® Fusion™ T2 is a second-generation two stage anode system used to control corrosion in reinforced concrete structures. Galvashield® Fusion T2™ is a Type 2 anode for embedment within drilled holes in sound concrete.

Galvashield® Fusion™ T2 is based on Fusion™ anode technology combining the performance of an impressed current electrochemical treatment (Stage 1) with the long-term maintenance-free capabilities of an alkali-activated galvanic anode (Stage 2). The Galvashield® Fusion™ T2 Anode automatically switches from Stage 1 to Stage 2 to provide long term, maintenance-free corrosion protection without complex wiring or an external DC power supply (temporary or permanent).

The anode selection and spacing are based upon the specific condition of the structure. Final designs utilize standard cathodic protection principles in accordance with ISO BS EN 12696:2016 and NACE RP0290 or can be based on achieving passivation in Stage 1 and cathodic prevention in Stage 2.

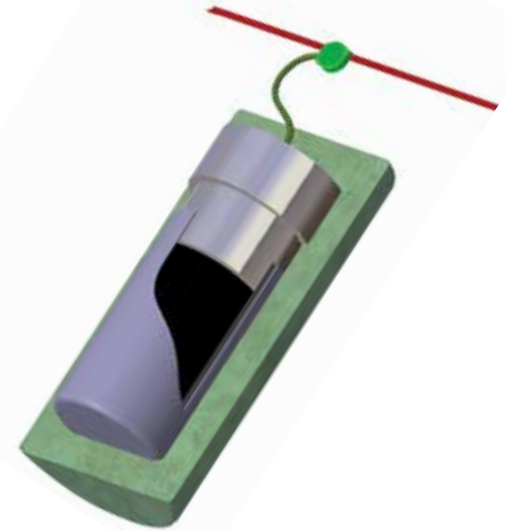

Cut-away of Galvashield® Fusion™ T2

## APPLICATIONS

- Multi-story Parking Structures
- Bridge Decks, Columns & Beams
- Marine Piers & Wharfs
- Balconies & Walkways
- Targeted or Global Protection

*\* As with all galvanic protection systems, service life is dependent upon a number of factors including reinforcing steel density, concrete conductivity, chloride concentration, humidity and anode spacing.*

Level of Protection	Description	Galvashield® Fusion T2
Corrosion Prevention	Mitigates initiation of new corrosion activity	•
Corrosion Control	Reduces on-going corrosion activity	•
Cathodic Protection	Reduces or eliminates on-going corrosion activity	•

## FEATURES AND BENEFITS

- **Proven Technology** - ICCP electrochemical treatment and alkali-activated galvanic anode technologies fused together into a single unit.
- **Simple Installation** - Galvashield® Fusion™ T2 is a single unit two stage system with no external power requirements.
- **Low Maintenance** - Galvashield® Fusion™ T2 operates automatically once installed, reducing access requirements and therefore time and cost.
- **Long Lasting** - Provides corrosion protection for up to 30+ years without the need for maintenance.\* Phase 1 can be designed to be repeated at any time if desired.
- **Measurable Performance** - While not critical for the long term operation of the system, the site performance can be measured and validated if required.
- **Modular** - Ideal for targeted protection to identified areas of corrosion risk (i.e. hot spots).

## SPECIFICATION

Embedded anodes shall be Galvashield® Fusion™ T2 anodes as designed by Vector Corrosion Technologies. The two phase anode shall be pre-manufactured and shall include a self-powered ICCP anode and an alkali-activated galvanic anode in a single unit. The galvanic anode shall have a zinc core produced with zinc in compliance with ASTM B418 Type II and be encased in an activated cementitious mortar with pH of 14 or greater. The anode unit shall contain no intentionally added chloride, bromide, sulphate or other constituents that are corrosive to reinforcing steel as per ACI document 222R.





# Galvashield® Fusion™ T2

## Self-Powered Two Stage Anode Series

### INSTALLATION INSTRUCTIONS

Galvashield® Fusion™ T2 anodes shall be installed in a single line or on a grid pattern as specified in the design document. Using a rebar locator, locate existing steel and mark areas to drill rebar connection holes and anode installation holes to avoid cutting steel. Rebar connection holes will be as per desired connection method as per below. When possible, anodes should be installed in the center of a reinforcing grid or a minimum of 100 mm (4 in.) away from steel. Drill all anode connection holes to the appropriate depth.

Anodes may be individually connected to the steel reinforcement or may be connected in a circuit as per the design. In either method be sure to confirm electrical continuity between all steel connections with a multimeter. A resistance of 1 ohm or less is acceptable.

**Individual Connection** - For individual connections, drill a single 12 mm (½ in.) rebar connection hole per anode unit location. Sawcut a groove approximately 6 mm (¼ in.) wide by 12 mm (½ in.) deep into the concrete to interconnect the rebar connection hole and anode connection hole. Reinforcing steel connections should be made using the Vector Rebar Connection Kit. After cleaning out the hole, place the weighted end of the steel connector into the drilled hole until the steel coil contacts the reinforcing steel. Feed the steel connector wire through the Vector Setting Tool and set into place by striking with a hammer.

**Series Connection** - For installing in series (daisy chain) a single circuit shall contain no more than twenty (20) Galvashield® Fusion™ T2 units. Reinforcing steel connections should be made using the Vector Anode Connection Kit or the Galvashield® Rivet Connector Pack.

When using the Vector Anode Connection Kit, drill a minimum of two 12 mm (½ in.) rebar connection holes per

string of anodes and sawcut a groove 6mm (¼ in.) by 12 mm (½ in.) linking the rebar connection holes to the anode connection holes. Install the rebar connectors as detailed above. The wire and connectors supplied in the Vector Anode Connection Kit will be used to link rebar connections to the anode units.

If using Galvashield® Rivet Connectors, chip 50 mm (2 in.) holes to expose rebar in two locations. Electrical connection to the steel shall be established by drilling a 5-7mm (0.2 to 0.28 in.) deep hole into the steel using the 3.5mm (0.14 in.) drill bit provided. 3.2mm (⅛ in.) stainless steel pop rivets are used to connect the connection wire to the steel. The connection shall be insulated by a neutral cure sealant or epoxy.

**Anode Installation** - Prewet the holes and the anodes to a saturated surface dry condition, then install with Galvashield® Embedding Mortar. Mix one 20 kg bag of mortar with 3.2 to 3.9 litres of potable water (3.4 to 3.9 quarts per 44 lb. bag). Add the powder to the water and mix with a drum or paddle mixer until a smooth consistency is achieved. Do not use partial bags.

Place the mixed embedding mortar into the bottom 2/3 of each hole and slowly press the anode into the mortar, allowing the mortar to fill the annular space ensuring there are no air voids between the anode and the parent concrete. The minimum cover depth over the anodes shall be 20 mm (¾ in.). A resistance of 1 ohm or less is acceptable.

Connect the anodes to the interconnecting header wire with the supplied connectors (wire and connectors are available as the Vector Anode Connection Kit or as the Galvashield® Rivet Connector Kit).

Place wires into grooves and top off anode holes and saw cuts flush to the concrete surface with embedding

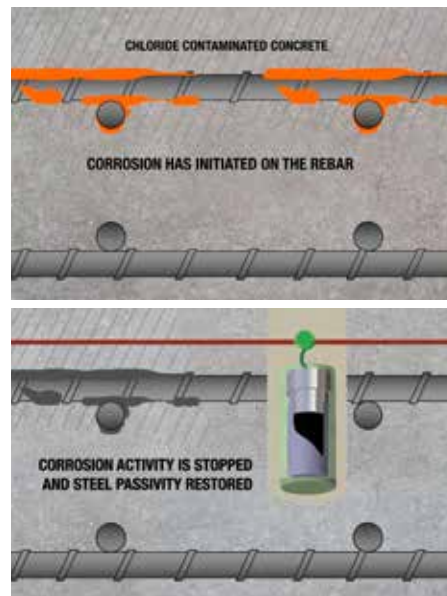

Typical Installation

mortar. Ensure there is sufficient concrete cover over all wires. Embedding mortar should be wet cured or cured with a curing compound and protected from traffic for 24 hours.

### STORAGE

Store in dry conditions in the original unopened box. Avoid extremes of temperatures and humidity.

#### Please note:

- Minimum hole dimension is 30 mm (1 ¼ in.) deeper than the anode length and 6 mm (¼ in.) wider than the anode diameter.





# Galvashield® Fusion™ T2

Self-Powered Two Stage Anode Series

## DESIGN CRITERIA

### Standard Units

Unit	Description	Unit Size diameter x length	Minimum Hole Size diameter x depth
T2 Standard	Large capacity two stage anode	46 x 105 mm (1 3/4 x 4 1/8 in.)	50 x 135 mm (2 x 5 5/16 in.)
T2 Slim	Small diameter two stage anode	29 x 135 mm (1 1/8 x 5 3/8 in.)	35 x 165 mm (1 3/8 x 6 1/2 in.)
T2 Custom	Custom as per design	Per Design	Per Design

## PRECAUTIONS

Galvashield® Fusion™ T2 anodes are not intended to address or repair structural damage. Where structural damage exists, consult a structural engineer.

Any discontinuous steel should be either electrically connected or isolated. Complete concrete repairs prior to the installation of Galvashield® Fusion™ T2 anodes.

## PACKAGING

Galvashield® Fusion™ T2 anodes	20 units per box, weight varies.
Galvashield® Embedding Mortar	20 kg (44 lb.) bags, one bag per 40-80 units
Vector Rebar Connection Kit	Contains 20 steel connections and 20 anode connectors per kit. Innovative design allows for quick rebar connections to be made.
Vector Anode Connection Kit	Contains 15m (50 ft.) insulated cable, 25 anode connectors, and 5 steel connections per kit. For use when Galvashield anodes are installed in series.
Vector Setting Tool	1 unit per box
Galvashield® Rivet Connector Pack	5 stainless steel rivets, 2 drill bits 23 wire connectors, 15 m (50 ft.) insulated wire

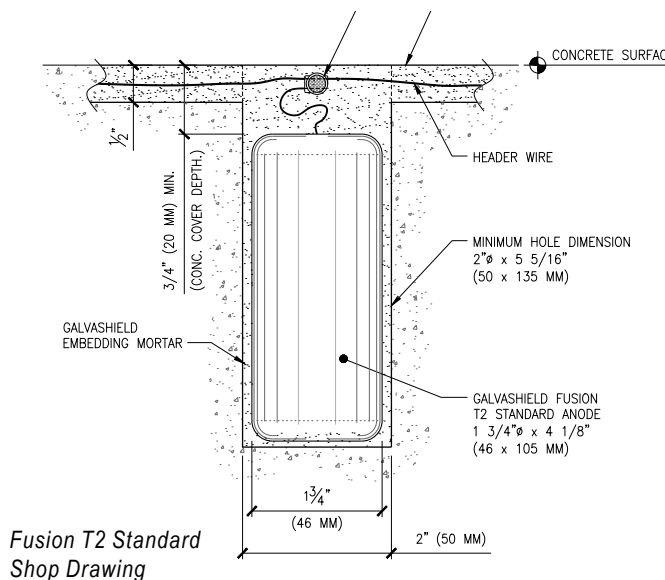



# Galvashield® Fusion™ T2

Self-Powered Two Stage Anode Series

## HEALTH AND SAFETY

As with all cement-based materials, contact with moisture can release alkalis which may be harmful to exposed skin. Galvashield® Fusion™ T2 and Galvashield® Embedding Mortar should be handled with suitable gloves and other personal protective equipment in accordance with standard procedures for handling cementitious materials. Dispose of excess material as per local requirements. Additional safety information is included in the Safety Data Sheet.

## ABOUT VECTOR

Vector Corrosion Technologies takes pride in offering technically advanced, cost effective corrosion protection solutions to extend the service life and improve the durability of concrete and masonry structures around the world. Vector has earned numerous project awards and patents for product innovation and is committed to a safe, healthy and sustainable environment.

For additional information on concrete preservation and sustainability, visit **WeSaveStructures.Info**. For additional information or technical support, please contact any Vector office or our extensive network of international distributors.

### Vector Corrosion Technologies Ltd.

474B Dovercourt Drive  
Winnipeg, MB R3Y 1G4  
Phone: (204) 489-9611  
Fax: (204) 489-6033

info@vector-corrosion.com  
www.vector-corrosion.com

### Vector Corrosion Technologies, Inc.

8413 Laurel Fair Circle, Suite 200A  
Tampa, FL 33610  
Phone: (813) 830-7566  
Fax: (813) 830-7565

info@vector-corrosion.com  
www.vector-corrosion.com

### Vector Corrosion Technologies Limited

27A Upper High Street  
Cradley Heath, UK B64 5HX  
Phone: (44) 1384 671 400

infoEU@vector-corrosion.com  
www.vector-corrosion.eu

Rev. Feb. 2020

Galvashield®, Vector and the Vector logo are registered trademarks. Patents: US 9909220, RE40,672 6022469, 6303017, 6193857, and other US and international patents and patents pending.  
© 2020 Vector Corrosion Technologies.

